

NUMBER
C-1834017

3RD ANGLE PROJECTION

METRIC

THIS INFORMATION IS CONFIDENTIAL AND IS DISCLOSED TO YOU ON CONDITION THAT NO FURTHER DISCLOSURE IS MADE BY YOU TO OTHER THAN AMP PERSONNEL WITHOUT WRITTEN AUTHORIZATION FROM AMP (TAIWAN) LTD. DIMENSIONS IN MILLIMETERS. DO NOT SCALE PRINT.

DIST
PRINT
DW

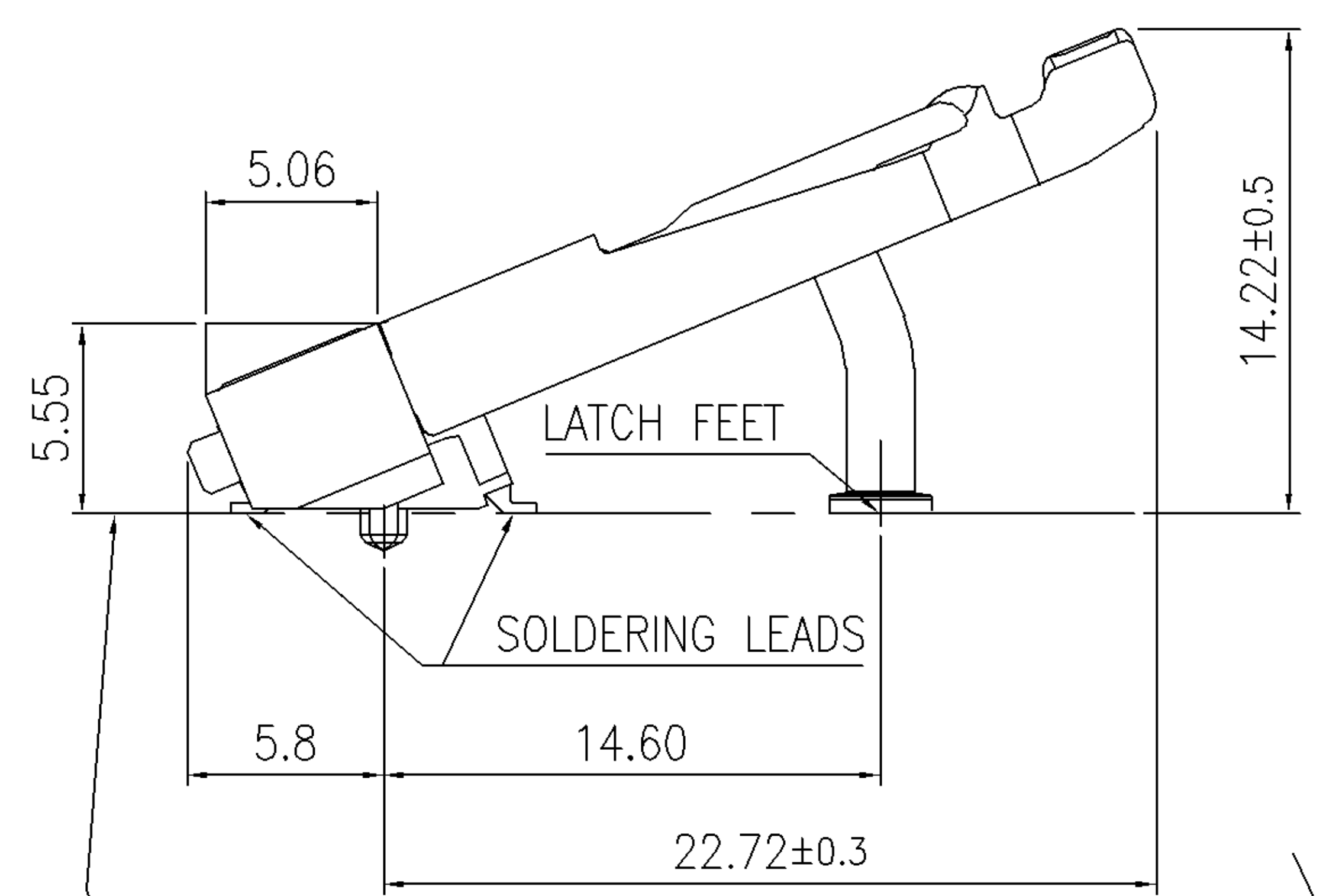
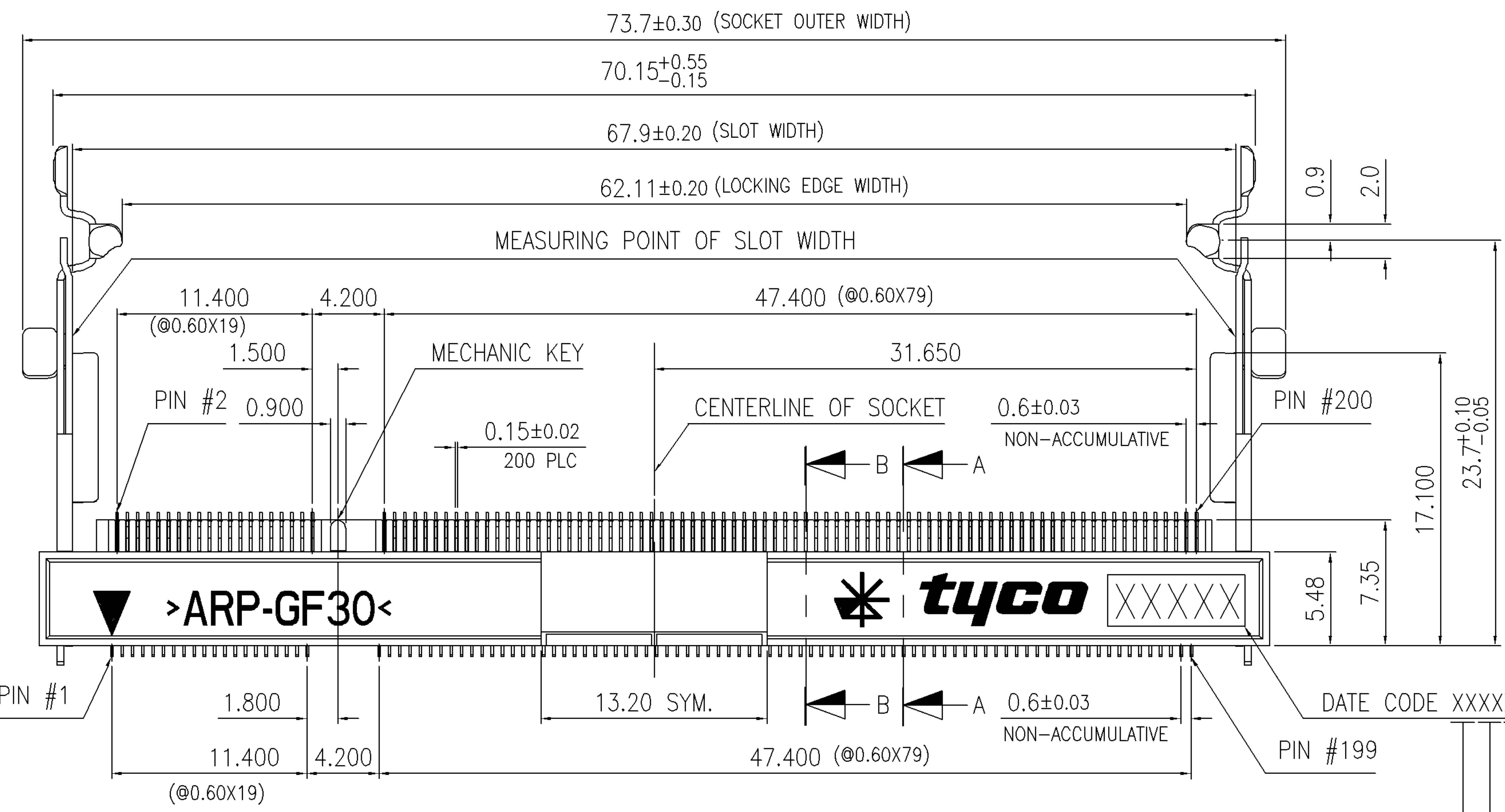
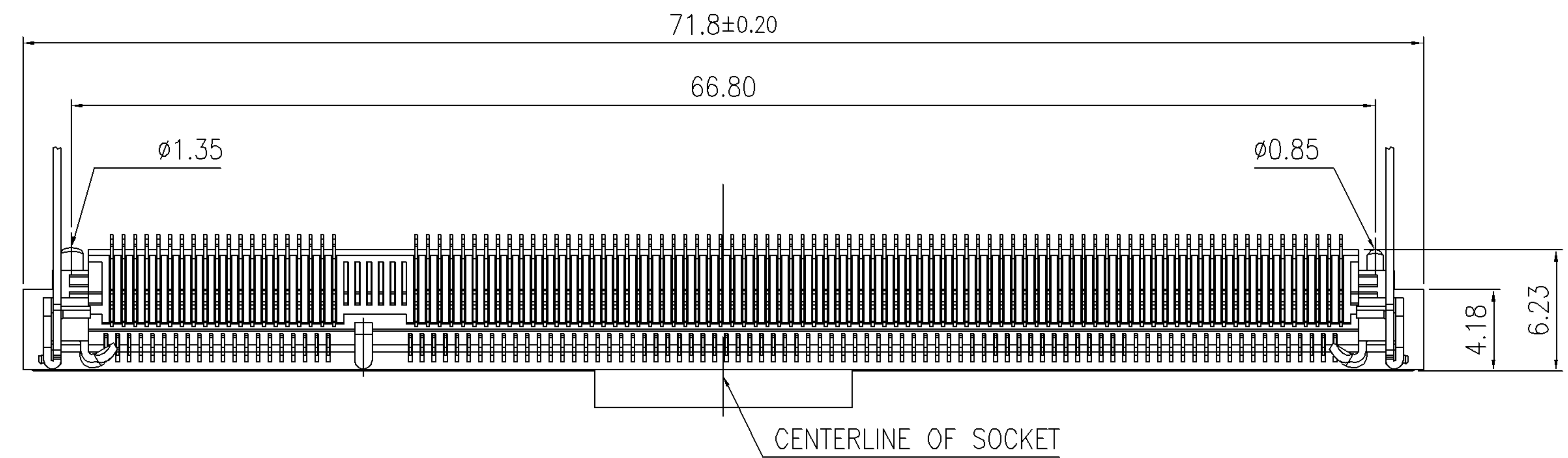

MOUNTING SURFACE OF P.C. BOARD
ALL SOLDERING LEADS AND LATCH FEET
MUST BE COPLANAR WITHIN 0.1 mm.

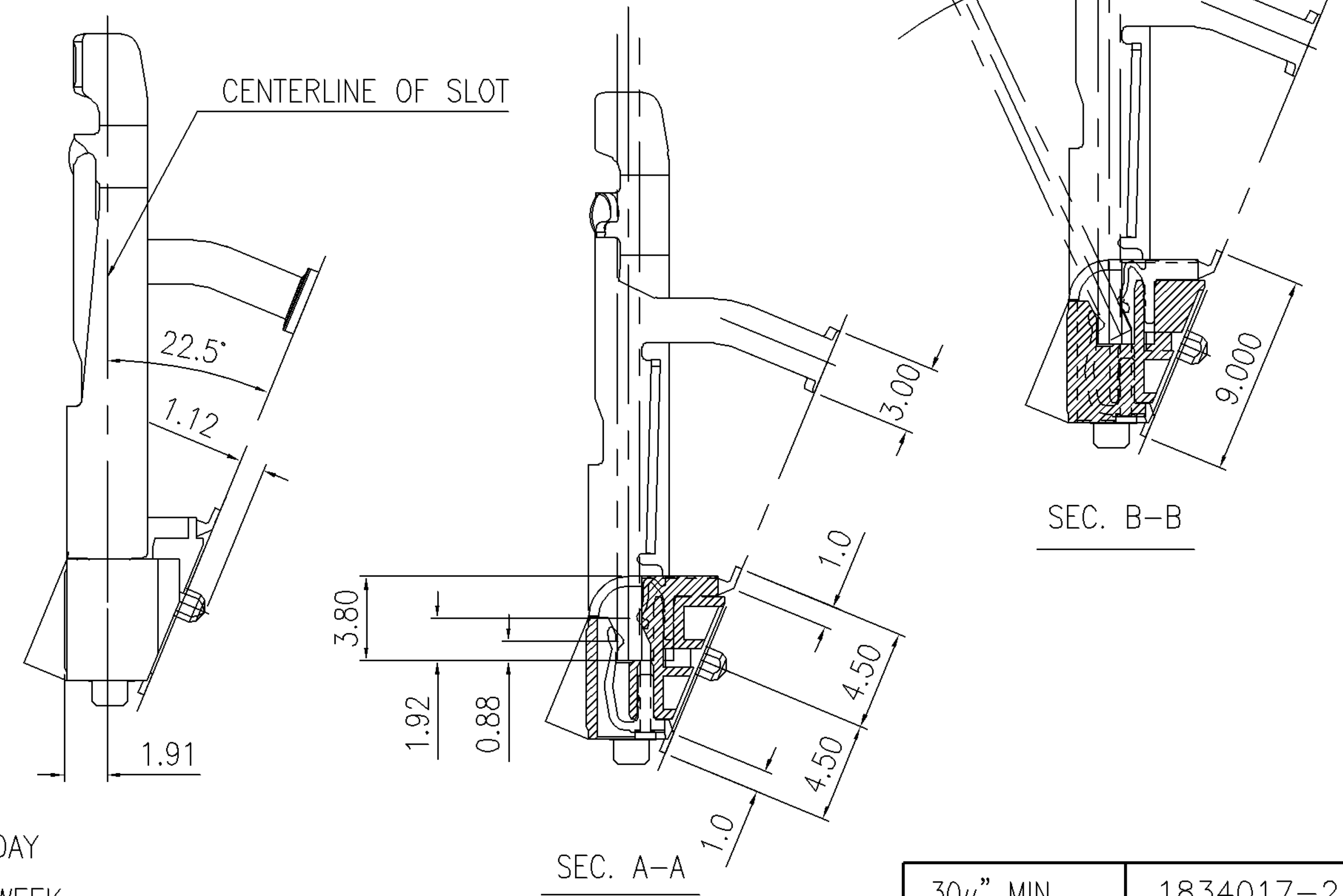

- NOTE:
- MATERIAL:
HOUSING: HIGH THERMOPLASTIC, 30% GF, UL 94V-0, COLOR: NATURE.
CONTACTS: PHOSPHOR BRONZE.
LATCH: STAINLESS.
 - FINISH:
CONTACTS: GOLD PLATED (SEE TABLE) ON CONTACT AREA, GOLD FLASH ON SOLDER TAILS, 50μ" MIN. NICKEL UNDERPLATED ALL OVER.
LATCH: 80μ" ~ 160μ" MATTE TIN PLATING 50μ" MIN. NICKEL UNDERPLATING OVERALL.
 - REFLOW SOLDER CAPABLE TO 260°C PER TYCO SPEC. 109-201, CONDITION B.

DATE CODE XXXXX
DAY
WEEK
YEAR

O	FIRST RELEASED	--	SH	19AUG
LTR	REVISION RECORD	ECN	DWN	2005
			CHK	DATE

TOLERANCES UNLESS OTHERWISE SPECIFIED: 0 PLC ±0.5 1 PLC ±0.2 2 PLC ±0.1 3 PLC ±0.05 ANGLES ±3'	DWN S. HOU 19-AUG-2005
MATERIAL SEE NOTE	CHK W.J. KE 19-AUG-2005
FINISH SEE NOTE	APVD W.J. KE 19-AUG-2005
	PRODUCT SPEC 108-57503
	QUALIFICATION TEST REPORT 501-57577
	WEIGHT

30μ" MIN.	1834017-2
10μ" MIN.	1834017-1
GOLD PLATED	PART NUMBER

tyco TYCO HOLDINGS (BERMUDA) VII LTD. TAIWAN BRANCH	
Electronics NAME	
ANGLED SO DIMM SOCKET ASSY, 0.6mm PITCH, 200 POSN, 22.5 DEGRESS, TILT FOR DRAM	
LOC DW	SIZE A ₃
DRAWING NO C-1834017	REV O
SCALE --	SHEET 1 OF 4

8 7 6 5 4 3 2 1 CUSTOMER DRAWING

THIS INFORMATION IS CONFIDENTIAL AND IS DISCLOSED TO YOU ON CONDITION THAT NO FURTHER DISCLOSURE IS MADE BY YOU TO OTHER THAN AMP PERSONNEL WITHOUT WRITTEN AUTHORIZATION FROM AMP (TAIWAN) LTD. DIMENSIONS IN MILLIMETERS. DO NOT SCALE PRINT.

PRINT DIST
DW

METRIC

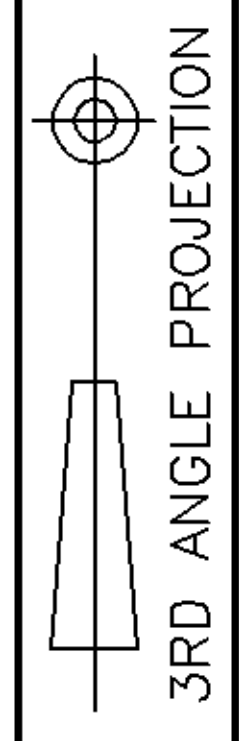

NUMBER
C-1834017

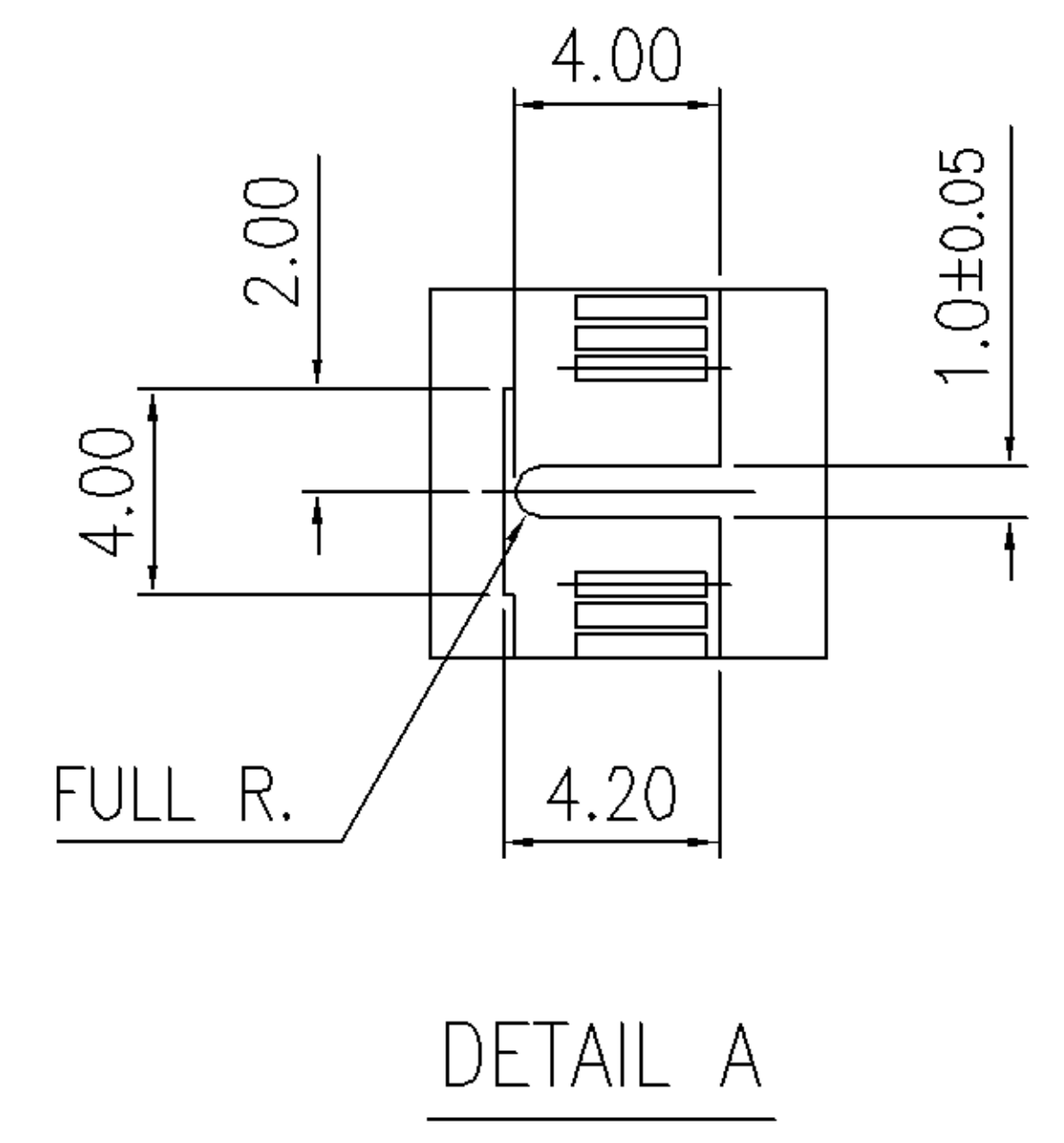
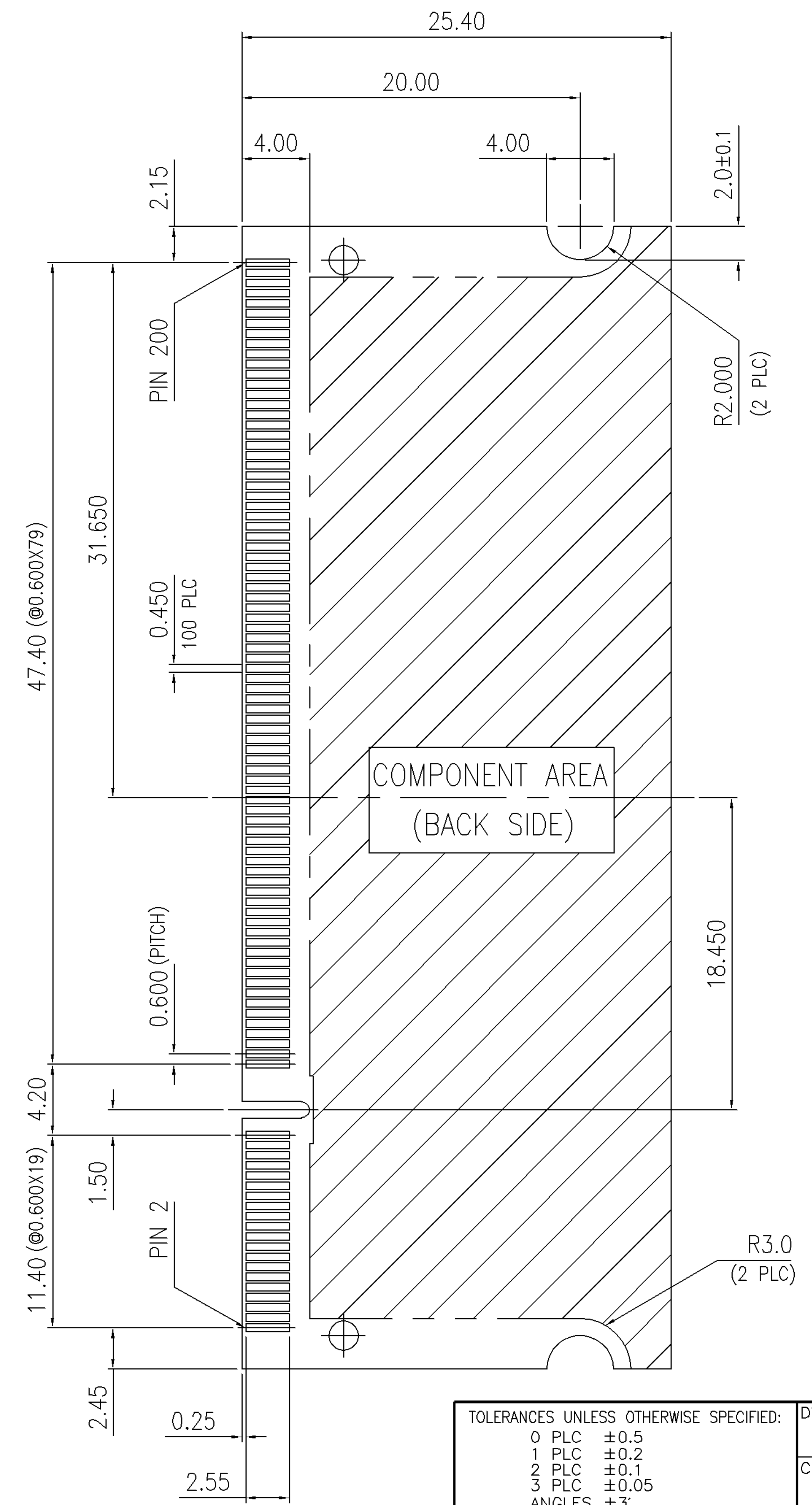
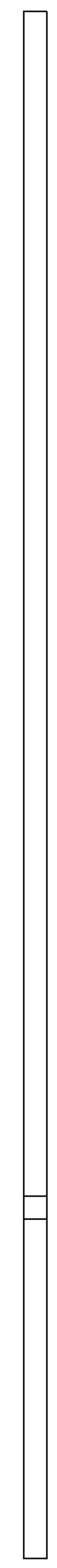
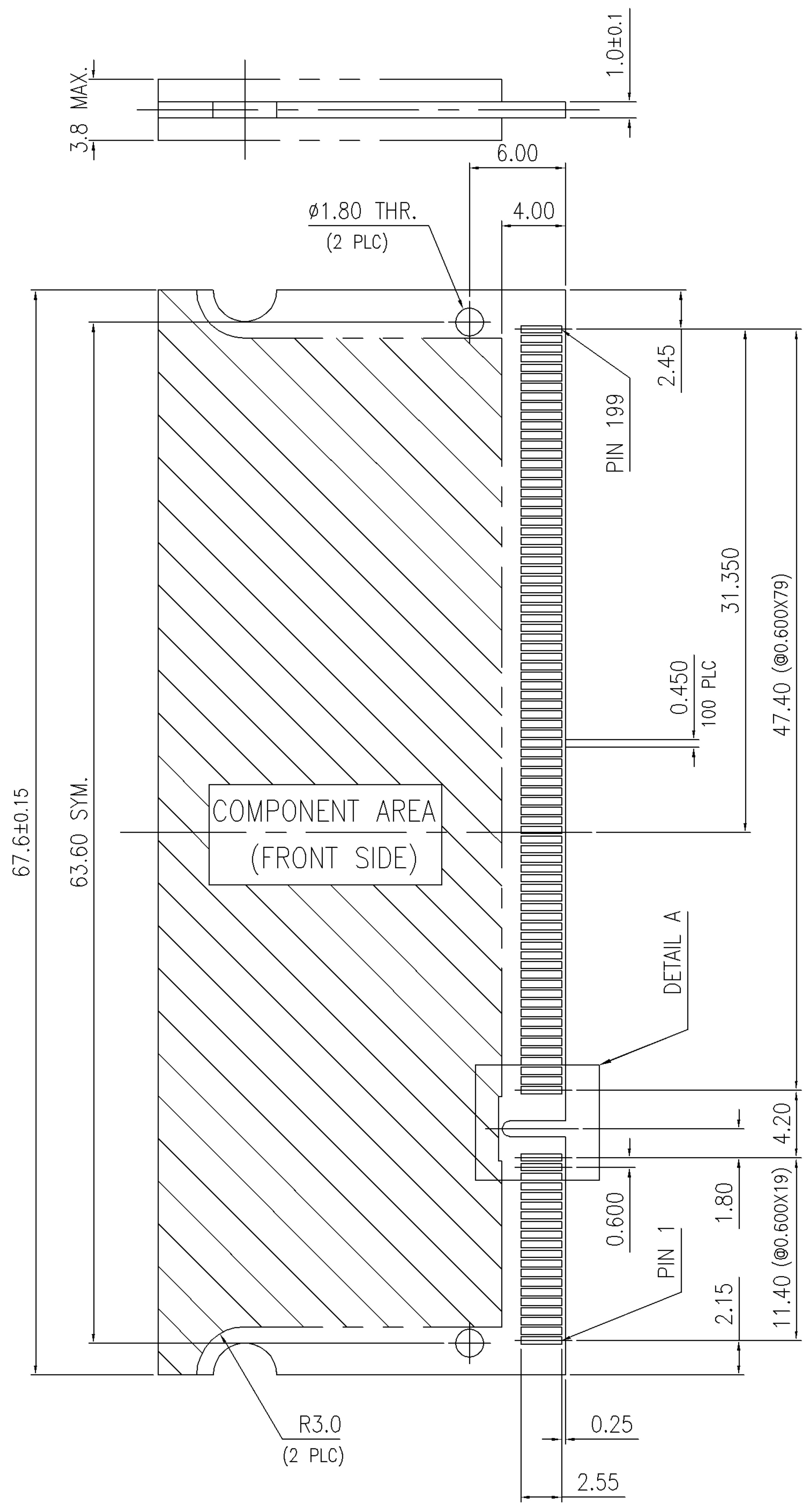

SEE SHEET 1.	ECN	DWN	CHK	DATE
LTR	REVISION RECORD			

TOLERANCES UNLESS OTHERWISE SPECIFIED: 0 PLC ±0.5 1 PLC ±0.2 2 PLC ±0.1 3 PLC ±0.05 ANGLES ±3'	DWN S. HOU 19-AUG-2005
MATERIAL -	CHK W.J. KE 19-AUG-2005
FINISH -	APVD W.J. KE 19-AUG-2005
WEIGHT	PRODUCT SPEC -
	QUALIFICATION TEST REPORT -

TYCO HOLDINGS (BERMUDA) VII LTD. TAIWAN BRANCH		NAME	
ANGLED SO DIMM SOCKET ASSY, 0.6mm PITCH, 200 POSN, 22.5 DEGREE, TILT FOR DRAM		LOC	
SIZE	DRAWING NO	REV	
A ₃	C-1834017	O	
SCALE	SHEET		
--	2 OF 4		

8 7 6 5 4 3 2 1 CUSTOMER DRAWING

D C B A

NUMBER
C-1834017

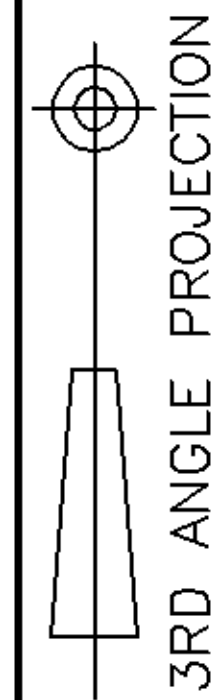

METRIC

THIS INFORMATION IS CONFIDENTIAL AND IS DISCLOSED TO YOU ON CONDITION THAT NO FURTHER DISCLOSURE IS MADE BY YOU TO OTHER THAN AMP PERSONNEL WITHOUT WRITTEN AUTHORIZATION FROM AMP (TAIWAN) LTD. DIMENSIONS IN MILLIMETERS. DO NOT SCALE PRINT.

PRINT DIST
DW

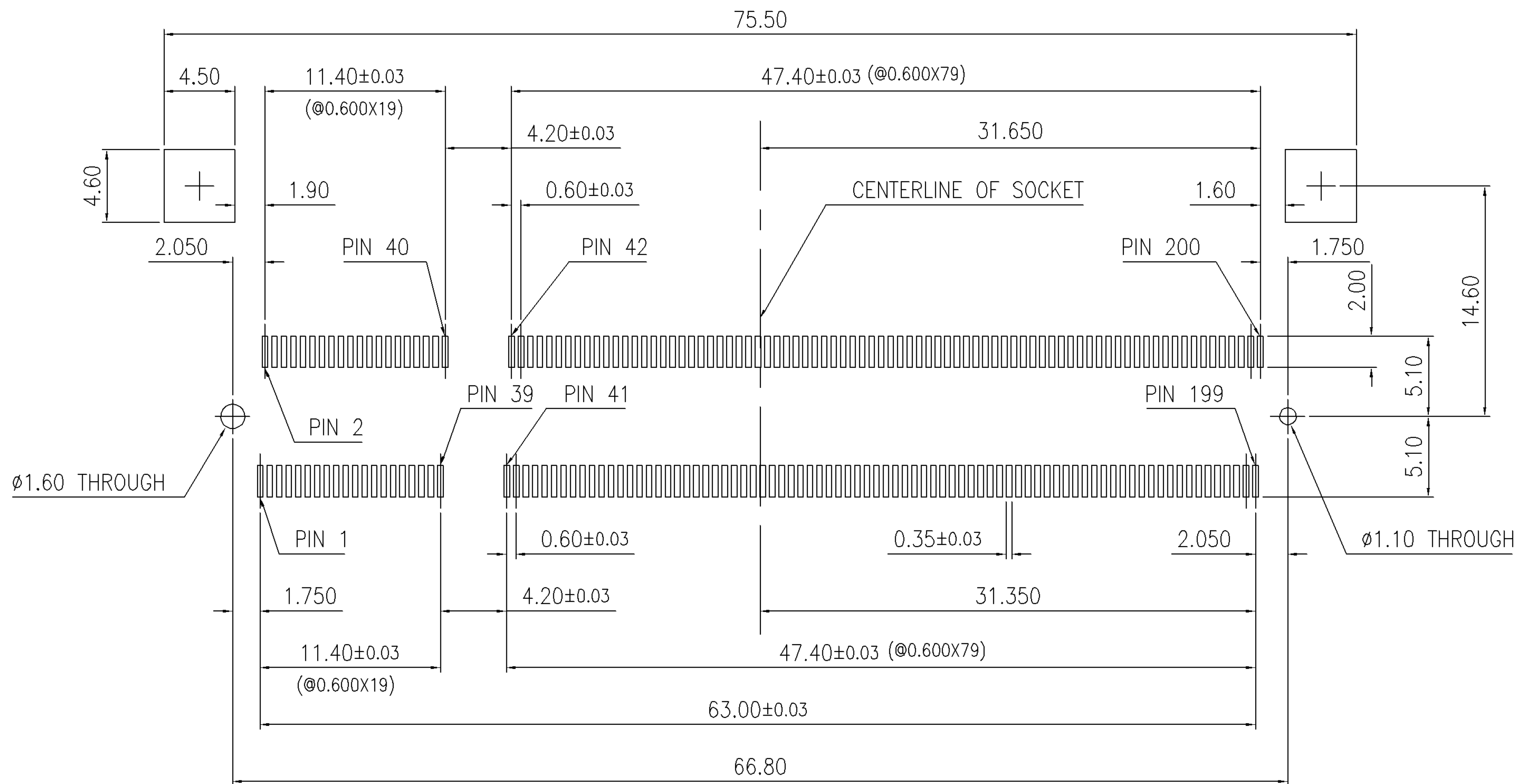

SEE SHEET 1.	ECN	DWN	CHK	DATE
LTR	REVISION RECORD			

TOLERANCES UNLESS OTHERWISE SPECIFIED: 0 PLC ±0.5 1 PLC ±0.2 2 PLC ±0.1 3 PLC ±0.05 ANGLES ±3'	DWN	S. HOU	TYCO HOLDINGS (BERMUDA) VII LTD. TAIWAN BRANCH	
	19-AUG-2005	19-AUG-2005		
MATERIAL -	CHK	W.J. KE	NAME	
	19-AUG-2005	19-AUG-2005	ANGLED SO DIMM SOCKET ASSY, 0.6mm PITCH, 200 POSN, 22.5 DEGRESS, TILT FOR DRAM	
FINISH -	APVD	W.J. KE	LOC	SIZE
	19-AUG-2005	19-AUG-2005	DW	A ₃
PRODUCT SPEC -	QUALIFICATION TEST REPORT -	DRAWING NO	C-1834017	REV O
WEIGHT	SCALE	SHEET		3 OF 4

THIS INFORMATION IS CONFIDENTIAL AND IS DISCLOSED TO YOU ON CONDITION THAT NO FURTHER DISCLOSURE IS MADE BY YOU TO OTHER THAN AMP PERSONNEL WITHOUT WRITTEN AUTHORIZATION FROM AMP (TAIWAN) LTD. DIMENSIONS IN MILLIMETERS. DO NOT SCALE PRINT.

NUMBER
C-1834017

3RD ANGLE PROJECTION

METRIC

PRINT
DW

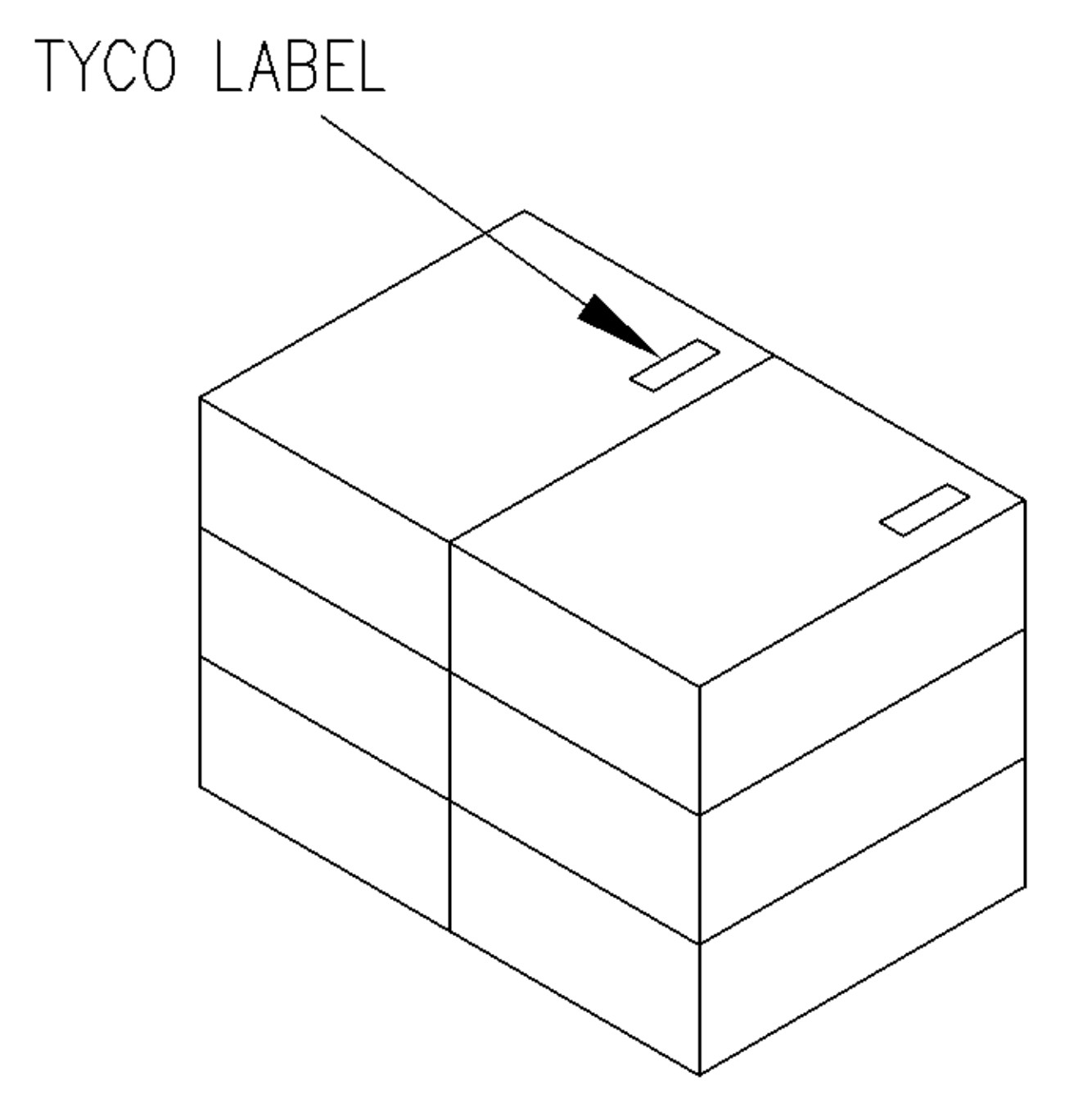
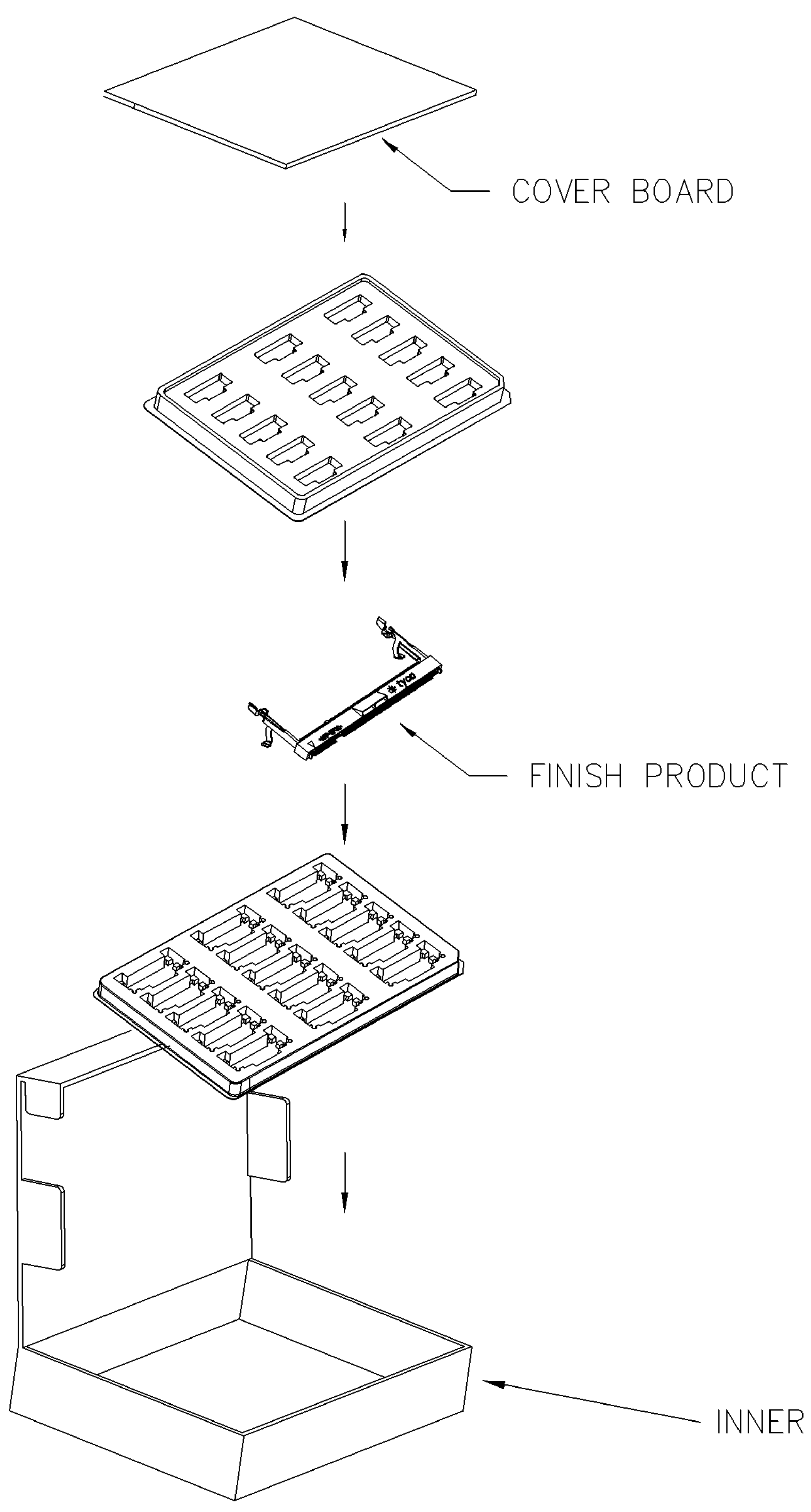

2 ROWS X 3 INNER BOXES
= 6 INNER BOXES

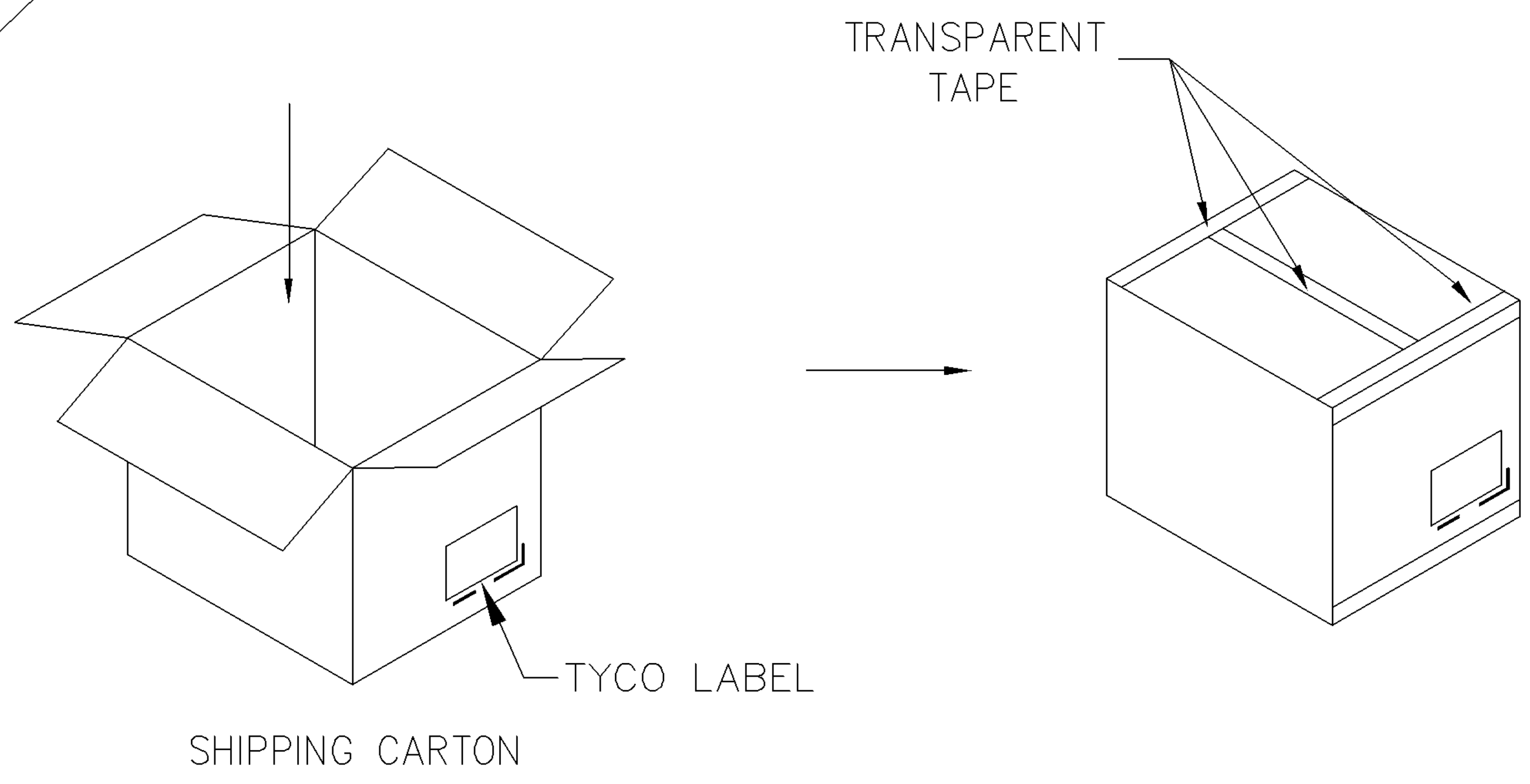

(1) DIMENSION
SEMI-HARD TRAY: 330x215x17.5 mm
INNER BOX: 35.5x23x6.5 cm
SHIPPING CARTON: 48x37x23 cm

(2) MATERIAL
SEMI-HARD TRAY: P.S.
INNER BOX: CORRUGATED FIBER
SHIPPING CARTON: CORRUGATED FIBER

(3) PACKAGING
15 PCS PER TRAY,
3 TRAYS PER INNER BOX,
6 BOXES PER SHIPPING CARTON.
QUANTITY: 270 PCS

(4) WEIGHT
N.W.: 1.196 KGs
G.W.: 4.5 KGs

SEE SHEET 1.	ECN	DWN	CHK	DATE
LTR	REVISION RECORD			

TOLERANCES UNLESS OTHERWISE SPECIFIED: 0 PLC ±- 1 PLC ±- 2 PLC ±- 3 PLC ±- ANGLES ±-	DWN	S. HOU	tyco TYCO HOLDINGS (BERMUDA)	
		19-AUG-2005	VII LTD. TAIWAN BRANCH	
MATERIAL -	CHK	W.J. KE	NAME	
		19-AUG-2005	ANGLED SO DIMM SOCKET	
FINISH -	APVD	W.J. KE	ASSY, 0.6mm PITCH, 200 POSN,	
		19-AUG-2005	22.5 DEGRESS, TILT FOR DRAM	
	PRODUCT SPEC		LOC	SIZE
			DW	A ₃
	QUALIFICATION TEST REPORT		DRAWING NO	REV
			C-1834017	O
	WEIGHT		SCALE	SHEET
			--	4 OF 4